

# A Study on Influence of Beam Orientation in Engraving Using CO<sub>2</sub> Laser

E. Wangui, B.W. Ikua and G.N. Nyakoe

**Abstract**—In recent times, lasers have been adopted in specific areas of machining because of their unique qualities. There has been a lot of research on the factors that affect the laser machining process. However most of this research has been conducted when machining with the beam perpendicular to the workpiece while there are cases where a non-vertical beam may be preferred for instance when machining features at oblique angles to the surface. Examples of such features are the cooling holes in certain parts of the aero-engine components or in the making of vias. This paper discusses the various uses of lasers in general, and further focuses on challenges in using sealed gas, continuous wave CO<sub>2</sub> laser in engraving with a varying beam incidence angle. Experimental results showing the how the kerf width and machined depth vary with a changing beam incidence angle have also been presented.

**Keywords**—CO<sub>2</sub> laser, engraving, beam incidence angle.

## I. INTRODUCTION

**A** LASER is an optical oscillator in which packets of light energy called photons oscillate in an optical cavity and are amplified by stimulated emission.

The stimulation phenomenon was predicted by Albert Einstein in 1916. He hypothesized that if a molecule or an atom is in an excited state, it will give up its energy if acted upon by a quantum of the same energy [1].

If such radiation is contained in an optical cavity made of two parallel reflectors, then the radiation moves back and forth between the reflectors indefinitely unless lost through absorption by the cavity walls or by diffraction.

As the photons bounce to and from both reflectors they collide with each other giving rise to the stimulation process. This results into the optical cavity converting into an oscillator as the energy builds up continuously because of the unending collisions. If one of the reflectors is partially transparent, a laser beam of significant power will emerge. The laser beam has a characteristic wavelength depending on the lasing material. Lasers of wavelengths ranging from the ultra violet (UV) to the far infra red (FIR) range are available. The application of a laser in material processing depends on the absorption characteristic of the laser's wavelength.

In a laser system, lasing is achieved by the excitation of atoms or molecules of the lasing medium using sources such as flashlights and electrical energy. The excitation or pumping source is dependent on the type of laser.

E. Wangui, Department of Mechatronic Engineering, JKUAT (+254724667947; e-mail: wangui.es@eng.jkuat.ac.ke)

B.W. Ikua, School of Mechanical, Manufacturing and Materials Engineering, JKUAT (+254722286264; e-mail: ikua\_bw@eng.jkuat.ac.ke)

G.N. Nyakoe, Department of Mechatronic Engineering, JKUAT (+254721456661; e-mail: nyakoe@eng.jkuat.ac.ke)

A typical setup of a laser system is shown in Fig. 1.

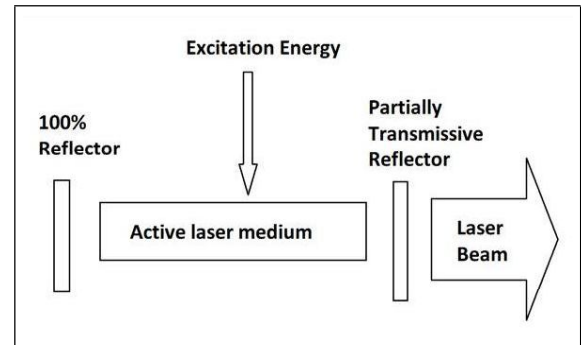

Fig. 1. A typical laser system

There are different types of lasers which include gas lasers, solid state lasers and dye lasers. These lasers find use in various areas including metrology, range finding, lithography, plating, marking, cutting, welding among others.

Gas lasers of which the most widely explored are the CO<sub>2</sub> lasers utilize CO<sub>2</sub> gas as the lasing medium and require electric charge as the pumping source. The CO<sub>2</sub> lasers could be flowing gas or sealed and have a wavelength,  $\lambda$ , of 10.6 $\mu\text{m}$  which is in the infra-red range. Industrial CO<sub>2</sub> lasers can be pulsed or continuous wave (CW). In CW operation, power is delivered continuously over a given time as opposed to pulsed operation where power is delivered in pulses of chosen duration over a given time.

The CO<sub>2</sub> laser is widely used in material processing applications such as surface treatment, drilling, welding and cutting. The CO<sub>2</sub> laser has a wavelength that is well absorbed by most organic materials and metals. The absorption of the CO<sub>2</sub> laser beam by metals is usually enhanced by applying anti-reflective coatings to the surface. Compared to the Nd:YAG laser which has a wavelength of 1.06  $\mu\text{m}$  and is also employed in many of the same applications as the CO<sub>2</sub> laser (see Table I [3]), the latter has a much higher efficiency. The power output of CO<sub>2</sub> lasers is also very wide ranging from a few watts to mega watts.

This paper discusses the various uses of lasers in general, and further focuses on challenges in using sealed gas, continuous wave CO<sub>2</sub> laser in engraving.

## II. IMPORTANT LASER PARAMETERS

The application of lasers is governed by a number of parameters which include the wavelength,  $\lambda$ , the spot size,

Table I  
COMMON APPLICATIONS OF INDUSTRIAL LASERS

Type	Operating mode	Power range(watts)	Applications
Nd:YAG	Pulsed	10 - 2000	A,B,C,D,E,F
Nd:YAG	Continuous	500 - 3000	A,B,C
Nd:YAG	Q-switched	5 - 150	D,E,F
CO <sub>2</sub>	Pulsed	5 - 3000	A,B,D,E
CO <sub>2</sub>	Superpulsed	1000 - 5000	A
CO <sub>2</sub>	Continuous	100-25,000	A,B,C
CO <sub>2</sub>	Continuous	3-100	D, E

Applications: A = cutting, B= welding, C = surface treatment  
D = drilling, E = marking, F = micro-machining

power and the characteristic of the material onto which the beam is irradiated. The laser's optical power has several special characteristics that make it advantageous for material processing. One of these is that the laser is highly directional over longer distances than conventional light. This is known as collimation and it allows the energy carried by a laser beam to be collected and focused onto a small area [2]. The divergence angle of the beam,  $\theta$ , has a minimum value when it is a function of diffraction at the beam's exit aperture only.

The diameter of a focused laser beam spot can be estimated by multiplying the published beam divergence value by the value of the focal length of the lens [3].

Irradiance,  $I$ , which is defined as power density per unit area is then

$$I = \frac{4P}{\pi D^2} \quad (1)$$

The essential feature of laser material processing is the very localized delivery of high irradiance something not possible with conventional light because of large divergence angles. Thus, lasers can be used for precision processing. They produce very large heating rates in the affected volume, leaving only small heat-affected zones. This makes laser processing advantageous when one desires to affect only a localized region [2].

It can be seen from equation 1 that high irradiance calls for lenses with short focal length. This may however not be practical since very small focal lengths will mean that the material being processed be very close to the lens and the debris and smoke may degrade the lens. Furthermore, small focal lengths lead to small depths of focus, DOF, for a given wavelength which is undesirable especially when machining a surface that is not flat.

The DOF is the distance over which the focused beam has approximately the same intensity. It is defined as the distance over which the focal spot size changes by  $\pm 5\%$  [3]. A sufficient DOF must be provided to compensate for vibration and any inaccuracy in positioning the workpiece [2], [3]

$$DOF = \pm \frac{d^2}{4\pi} \quad (2)$$

A further limit to the minimum focal length usable is aberrations and the most significant of which is the spherical aberration [2]. An aberration free lens would focus all light entering a lens onto one a single point in the focal plane. A lens with spherical aberrations tends to focus rays that enter

the lens close to the center of the lens to be focused to a point further along the focal axis than those entering the lens further away from its center. The result is a blurred or hazy image.

Another interesting characteristic of optical power regards its transmission. Optical power can be transmitted through air or vacuum and like electricity can also be transmitted through fibers giving it ease of application.

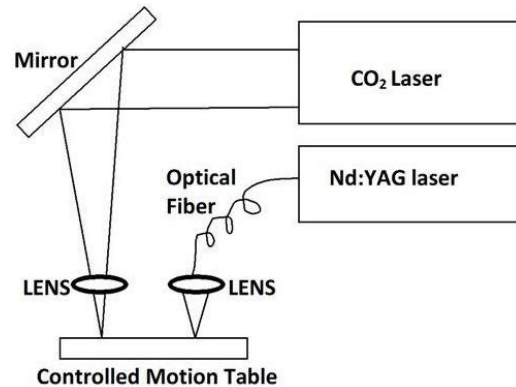

Fig. 2. Beam transmission in CO<sub>2</sub> and Nd:YAG lasers

Because CO<sub>2</sub> lasers are usually applied in medium to high power applications, (see I) the beam is delivered and controlled through a system of optics while solid state lasers such as the Nd:YAG laser are able to utilize fiber optic cables to deliver the beam to the workpiece.

### III. LASER-MATERIAL INTERACTION

When laser light is incident on a surface various phenomena may occur and they include reflection, refraction, absorption, scattering and transmission [5]. Of these, absorption is of great importance and interest because it results in effects such as temperature rise in the material which can be utilized in surface treatment processes as well as vaporization and chemical bond breaking that form the basis of several material removal techniques.

When laser energy is absorbed, material removal may result from photo-thermal effects or photo-chemical effects [5].

In photo-thermal absorption, heating of the material from the laser energy occurs. Further exposure to the radiation or increasing the intensity of radiation raises the temperature of the material to its melting point and change of phase occurs. If the temperature rises further and the boiling temperature is exceeded, then another phase change occurs and the melt evaporates and hence material is removed from the workpiece. Thus absorption in this case results in laser energy being converted to thermal energy being converted to thermal energy and the subsequent temperature rise may facilitate material removal through generation of thermal stresses [6].

In other instances, the incident energy can cause the direct bond breaking of molecular chains in the material resulting in material removal by molecular fragmentation without significant thermal damage. For photo-chemical ablation to occur,

then the photon energy must be greater than the molecular bond energy.

UV radiation with wavelengths in the range 193-335nm have corresponding photon energies that exceed the dissociation energy of many molecular bonds resulting in efficient photo-chemical ablation [5], [7].

However, even if the photon energy is less than the dissociation energy of a molecular bond, photo-chemical ablation is still possible. This is observed for longer wavelength radiation (with lower photon energies) and is due to bond breaking achieved by simultaneous absorption of two or more photons [5].

Therefore, laser-material interaction may involve material removal by both photo-thermal and photo-chemical processes. A parameter of interest in this regard is the thermal relaxation time  $\tau$ .  $\tau$  is related to the dissipation of heat during laser pulse irradiation and its value is given by [8]

$$\tau = \frac{d^2}{4\alpha} \quad (3)$$

Where  $d$  is the absorption depth and  $\alpha$  is the thermal diffusivity of the material.

For laser energy pulses with a duration longer than  $\tau$ , then the absorbed energy will be dissipated in the surrounding as the thermal energy. To favor photo-chemical ablation with minimal thermal effects, the pulse-on time must be shorter than the thermal relaxation time,  $\tau$ .

The CO<sub>2</sub> laser is well absorbed by inorganic materials such as paper and wood but when it comes to metals, the shorter wavelength of the Nd:YAG laser, 1.06  $\mu\text{m}$  compared to the CO<sub>2</sub> laser's 10.6  $\mu\text{m}$  is absorbed to a higher degree.

Compensation for the lower absorption of CO<sub>2</sub> light by metals is afforded by high density energy beams. The high energy densities create small surface temperature changes that tend to increase the beam coupling coefficient. At CO<sub>2</sub> power densities in excess of 10<sup>6</sup> W/cm<sup>2</sup>, effective absorptivity in metals approaches that of non metals. In broad-area beam processing where the energy density is low (10<sup>4</sup> W/cm<sup>2</sup>), some form of surface coating may be required to couple the beam energy into a metal surface [3].

#### IV. COMPARISON WITH OTHER MACHINING TECHNIQUES

Where lasers are used for machining, other methods can also be applied.

Abrasive waterjet machining, AWJM, is a process that utilizes a high velocity waterjet in combination with abrasive particles to remove material [9]. The main material removal mechanisms are erosion by cutting wear due to impact of the abrasive particles and the material at shallow angles and the second is deformation wear due to excessive plastic deformation caused by particle impact at large angles deeper into the workpiece [9], [10]. Unlike laser material removal, AWJM is a mechanical contact removal process and therefore mechanical stresses are imparted onto the surface being machined. There is also the wear of the abrasives which have to be replaced to maintain efficiency of the process.

Electrochemical machining, ECM, is a material removal process that is based on anodic dissolution of the workpiece

during electrolysis [9]. Electrolysis is a chemical process whose laws were established by Faraday in 1833. If two conductive poles are placed in a conductive electrolyte bath and energized by a current, metal may be depleted from the positive electrode, the anode and plated onto the negative electrode, the cathode. Like laser material removal, ECM is a non contact process. However compared to laser machined surfaces, ECM machined surfaces are characterized by brighter and smoother finishing. An advantage of laser material removal is that very localized material removal can take place whereas in ECM it is a challenge to confine the ECM process within the areas that must be machined as the whole workpiece is made an electrode. There is also the high tooling cost because of the need to produce a custom shaped tool for various geometries. The ease of beam control through optics make its more convenient to produce complex shapes using laser machining.

Because of the relative ease of beam control through optics it is easier to produce complex shapes through

#### V. APPLICATION OF CO<sub>2</sub> LASER IN MARKING AND ENGRAVING

Lasers in recent years have been used for marking. Product marking can be carried out for various purposes which include identification, for product information and imprinting distinctive logos. Conventional marking techniques include printing, stamping, mechanical engraving, manual scribing, etching and sandblasting. In some instances, need for durable permanent marks stretch place limitations on the capabilities of these techniques.

Laser marking offers a viable alternative to conventional methods. It offers several advantages. Virtually any material can be marked with high quality permanent marks. Since it is a non contact process, it minimizes mechanical distortion and does not introduce contamination. It is especially suitable in marking small, delicate, high value assemblies. The major limitation in the use of lasers for marking is that it is relatively expensive compared to competing technologies.

There are two approaches applied to laser marking [2]. In one approach, the laser is scanned across the surface and vaporizes the work at selected positions thus forming a mark. The mark can be an alphanumeric character or any other pattern. When marking is performed in a dot matrix pattern, a series of tiny holes defines the desired characters or figures. The high-power beam is focused on the surface, scanned in the desired pattern, and pulsed when a mark is needed.

The scanning technique has been employed for imprinting identification marks on products such as silicon wafers. Laser printing of identifying numbers on silicon wafers is attractive because of the brittleness of the material, because of the lack of contamination, and because later processing operations could destroy printed marks.

Laser engraving, provides a variation of the scanning method. The laser vaporizes the workpiece, etching grooves typically about 0.15 mm wide with vertical walls into material. The laser is operated to engrave making of any desired configuration.

The engraving technique has often been used to mark wood products for applications like fabrication of artistic scenes or commemorative plaques. This application often employs a CO<sub>2</sub> laser operating in the range of 40-80 W of power. The pattern may be stored in a computer memory, which controls the scanning and the modulation of the beam. This method allows rapid transformation of a drawing into an engraved pattern [2].

Another approach to laser marking is image micro machining. In this approach a high-power beam is focused onto a mask of some desired pattern and the image is formed on the workpiece in one pulse of the laser. The mask is placed in the path of the beam and a lens images the mask pattern on the surface and provided that the laser power is sufficiently high, the material is vaporized and a permanent image of the mark is imprinted (Fig. 3). The primary advantage of this approach is the ability to imprint large area patterns with a single pulse.

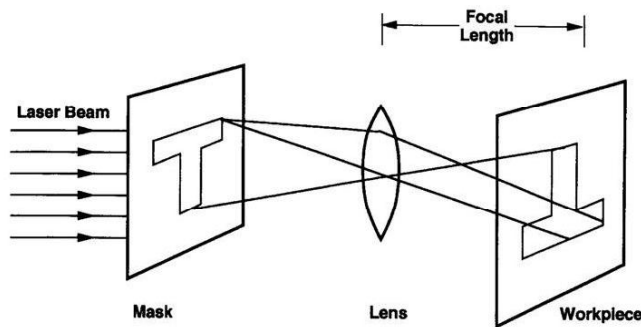

Fig. 3. Image micromachining using a laser beam

This is applicable to marking of soft materials with a low latent heat of vaporization such as organic materials like wood and paper. The CO<sub>2</sub> laser is commonly used for this purpose because its wavelength is well absorbed by organic materials [2].

## VI. CHALLENGES ASSOCIATED WITH LASER ENGRAVING

There has been considerable investigation of the factors that affect quality characteristics of laser machined features.

These factors may be process factors such as laser power, scanning speed and type of laser or material properties and characteristics such as type of material, conductivity, thickness.

A model of the bulge formation during laser machining of polymers has been done by Ndeda [11].

In that study it was found that increasing laser power when cutting increased the heat affected zone and consequently increasing the probability of the formation of bulges. Also, increasing the scanning speed a power of 50W prevented large amounts of re-solidified material in the cut channels.

Chen [12] found kerf width increased with increasing laser power and decreasing cutting speed when 3mm mild steel sheets with a CO<sub>2</sub> laser. It was also found that when using assisting gas, oxygen resulted in a wider kerf width while inert gases produced the smallest kerf width.

Rajaram et al. [13] investigated the effects laser power and speed on the surface roughness as well as striations which are periodic lines appearing on the surface. Their experiments proved that choosing an optimum feed rate would reduce the surface roughness, though laser power had little effect on roughness and practically no influence on striation frequency.

While Lum et al. [14] observed that using pulsed CO<sub>2</sub> laser cutting generally produced better surface finish than cutting in CW mode.

There are challenges associated with laser engraving. One of these is introduction of a heat affected zone, HAZ. For the engraving operations performed with a CW laser, the continuous exposure time to the irradiation creates the possibility of HAZ in the areas surrounding the mark being made.

The surfaces being engraved are not always flat and may have changing profiles or free form shapes.

Other times it is may be desired to produce features at oblique angles to the surface such as production of cooling holes in certain parts of the aero-engine components [15] or vias. In this case, the laser beam is no longer perpendicular to the area being machined and the effect of the angle of incidence of the beam has to be considered.

Sezer et.al [15] investigated the influence of the beam's incidence angle on reducing the HAZ, the recast layer and the oxide layer when drilling nickel super alloys coated with thermal barrier coatings, TBC. They found that increasing the beam angle as it impinged the material decreased the HAZ, recast and oxide layers upto an incidence angle of 60°. Beyond this angle, the value of the three attributes remained constant

It is the subject of a current study investigate the effect of the angle of incidence on depth of cut, width of cut and surface roughness of a laser machined feature.

### A. Influence of the beam incidence angle

Consider a laser beam directed perpendicular to the work piece and let the diameter of the beam after focusing be  $d$ . In 2-D, Fig. 4 would depict the set-up where  $h$  is the focal length.

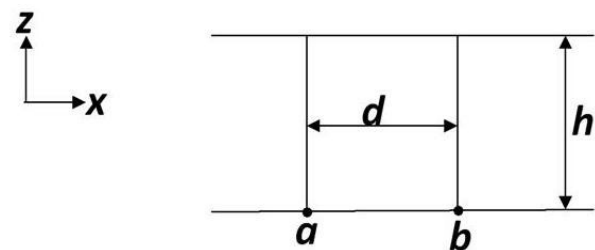

Fig. 4. Laser beam normal to the workpiece

The focal spot area projected onto the work piece, would be a circle of diameter  $ab = d$ .

The spot area is given by

$$\text{Spot area} = \frac{\pi d}{4}$$

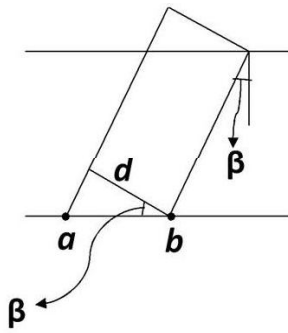

Fig. 5. Beam incident angle at an angle  $\beta$  to the worktable normal

Let the incident angle of the beam be rotated by an angle  $\beta$  in the  $z-x$  plane.

In this case, the area projected onto the work piece by the aperture would be an ellipse with a major axis of length  $ab$ .

Since inclination of the beam incidence angle only occurred in the  $z-x$  plane, the spot area now becomes an ellipse whose minor axis' length is equal to the diameter after focusing  $d$ , but whose major axis' length  $ab$  is given by

$$ab = \frac{d}{\cos \beta}$$

The area of an ellipse is the product of  $\pi$ , the minor radius and major radius and therefore the spot area now becomes

$$\text{Spot area} = \frac{\pi d}{4 \cos \theta}$$

As change in spot area changes the irradiance on a surface, it is worthwhile to study the changes in characteristics of a laser machined feature due to this.

The amount of incident laser energy absorbed by a material is influenced by properties such as reflectivity and absorptivity. Absorptivity defined as the fraction of incident light absorbed at normal incidence and for opaque materials, absorptivity  $A$  is given by [5]

$$A = 1 - R$$

where  $R$  is reflectivity of the material.

Reflectivity and absorptivity of the material can be calculated from optical constants or from the complex refractive index  $n_c$  given by

$$n_c = n - ik$$

where  $n$  and  $k$  are the refractive index and extinction coefficient respectively both of which are strong functions of wavelength and temperature. The reflectivity at normal incidence is then defined as

$$R = \frac{(n-1)^2 + k^2}{(n+1)^2 + k^2}$$

Reflectivity of metals generally increases with increase in the wavelength of radiation and that is why they will absorb radiation from an Nd:YAG laser ( $\lambda = 1.06\mu m$ ) better than that from the CO<sub>2</sub> laser ( $\lambda = 10.6\mu m$ ). Reflectivity will

also decrease with increase in temperature and a material that is strongly reflective at low temperature may become strongly absorbing at higher temperatures. This is of particular importance when laser processing materials where interaction causes significant increase in surface temperatures.

The angle of incidence of polarized radiation also affects reflectivity of a material [5] and at a certain angle known as the Brewster angle, the reflectivity is zero for the component of linearly polarized light that is perpendicular to the plane of polarization. This component is referred to as the p-component. Reflectivity of a perfectly flat surface for the p-component is given by [16]

$$R_p = \frac{(n - \frac{1}{\cos \theta})^2 + k^2}{(n + \frac{1}{\cos \theta})^2 + k^2} \quad (4)$$

where  $\theta$  is the angle of incidence of the radiation. It would be of interest to find out if the change in reflectivity due to change the angle of incidence of the laser beam is enough to cause significant changes in machined features.

## VII. ON-GOING RESEARCH WORK

As part of ongoing research work, it is sought to investigate the influence the beam incidence angle changes has on the depth, width and surface roughness of the machined feature for a particular laser power and laser scanning speed.

A laser material processing system contains many components other than the laser. By itself, the laser could not successfully carry any application.

In general, a complete system may have the laser and laser power supply, a gas management system if necessary, probably a beam delivery system, a shutter, beam focusing optics, possibly gas jets, usually a power monitoring device, fixturing for holding and moving the workpiece, sometimes equipment for moving the beam, appropriate safety devices and interlocks, possibly equipment for monitoring the effect of the beam on the workpiece, and often programmable drives for automatically positioning the workpiece and programmable controllers for driving the laser. For the application to be successful, all parts of the system must be carefully designed and chosen [2].

For the current work, a laser beam delivery system has been developed. It consists of a structure with two perpendicular axes which carry beam guiding mirrors and the lens. Also incorporated in the mechanical structure is a worktable. The movement of the axes is controlled by a machine control software. The laser equipment is a 60W continuous wave CO<sub>2</sub> laser and is kept stationary. The workpieces are placed onto the worktable and the beam is guided over them by the moving system of mirrors and lenses. These materials machined are perspex and soda lime glass. Machining will be done by varying the angle of incidence of the laser beam, and for each angle, the material will be engraved at different speeds. After machining, the width, profile and depth of cut shall be measured using a projector and analyzed. The surface roughness will be measured using a profilometer.

Some preliminary results for engraving perspex are presented in Fig. 6 and Fig. 7. Variation of the kerf width and depth of cut with the beam incidence angle is shown. From Fig. 6, it can be seen that the kerf width increases with increase in beam incidence angle for all speeds. Generally, it is also clear that the kerf width is larger when machining at low speeds than when engraving at high speeds. In Fig. 7, the machined depth is seen to decrease with increasing beam incidence angle for all speeds and also decreases with increasing cutting speed.

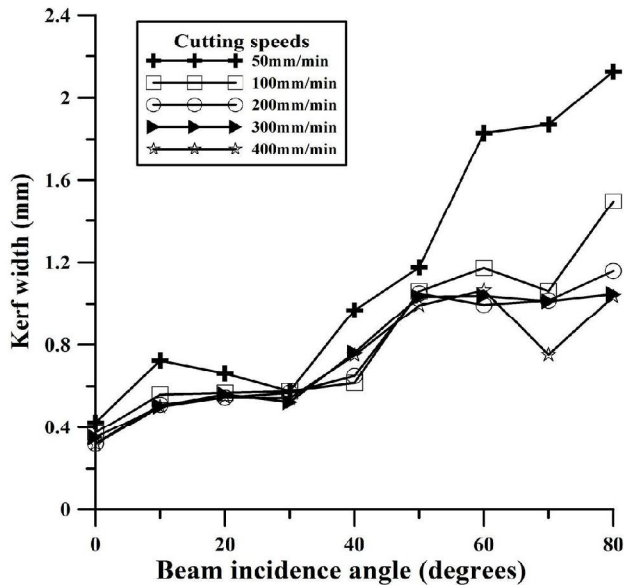

Fig. 6. Kerf width vs Incidence angle for different speeds

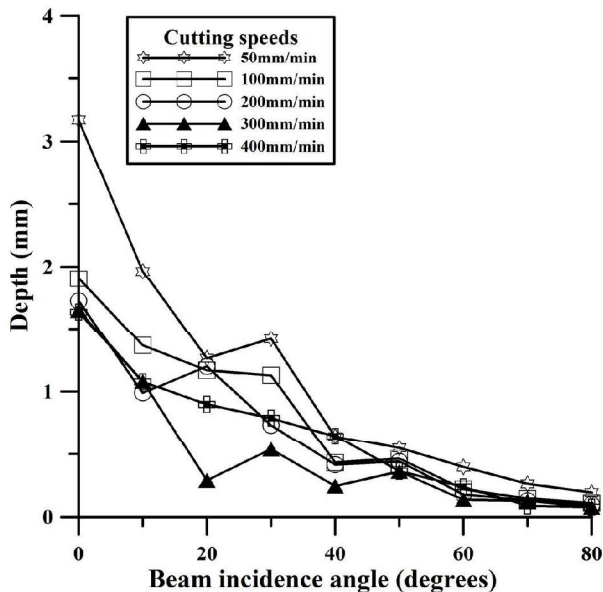

Fig. 7. Depth of cut vs Incidence angle for different speeds

## VIII. CONCLUSION

This paper has given an overview of laser machining and discussed the various challenges encountered in the process. Specific attention has been given to engraving with CO<sub>2</sub> laser, for which experiments have been carried out. Experimental results show that the kerf width increases with increasing beam incidence angle while the machined depth reduces. Furthermore, the results also indicate a larger kerf width and machined depth for lower cutting speeds than when engraving at high speeds.

## ACKNOWLEDGMENT

This work is supported by Jomo Kenyatta University of Agriculture and Technology, JKUAT. The authors would like to acknowledge Mr. Joshua Owiyo and Mr George Kariuki of the engineering workshops, JKUAT and Mr. Boniface Kariuki of the Department of Mechatronic Engineering, JKUAT, for their assistance.

## REFERENCES

- [1] W. M. Steen, *Light industry: an introduction to laser processing and its industrial applications* Advances in laser materials processing Technology, research and applications 2010.
- [2] J.F. Ready., "Industrial Applications of Lasers". Academic Press, 1987.
- [3] Robert E. Green, *Machinery's Handbook, 25th Edition* Industrial Press INC, 1996
- [4] W.M. Steen, *Laser Material Processing* Springer-Verlag, 1991.
- [5] Nahendra B. Dahotre, Sandip P. Harimkar, *Laser Fabrication and Machining of Materials*, Springer Science, 2008.
- [6] Buerle D., *Laser Processing and Chemistry*. Springer, Berlin., 2000.
- [7] Vogel A., Venugopalan V., *Mechanisms of pulsed laser ablation of biological tissues.*, Chemical Reviews 103:577644., 2003.
- [8] Thompson K.P., Ren Q.S., Parel J.M., *Therapeutic and diagnostic application of lasers in ophthalmology.*, In: Waynant RW (ed) Lasers in Medicine, CRC Press, Boca Raton, FL., 2002
- [9] R. Venkata Rao, *Advanced Modeling and Optimization of Manufacturing Processes*, Springer, 2011.
- [10] Hashish M., *A model for abrasive waterjet(AWJ) machining.*, Transactions of ASME Journal of Engineering Materials and Technology, vol. III, 1989.
- [11] R. Ndeda, *Modeling of bulge formation in polymers during laser micromachining* M.Sc Thesis in Mechatronic Engineering, 2011.
- [12] S.L. Chen, *The effects of high-pressure assistant-gas flow on high power CO<sub>2</sub> laser cutting*, Journal of Material Processing Technology 88 5766, 1999.
- [13] N. Rajaram, J.S. Ahmad, S.H. Cheraghi, *CO<sub>2</sub> laser cut quality of 4130 steel*, International Journal of Machine Tools and Manufacture 43 351358, 2003.
- [14] K.C.P. Lum, S.L. Ng, I. Black, *CO<sub>2</sub> laser cutting of MDF 1. Determination of process parameter settings*, Optics and Laser Technology 32 6776. 2000.
- [15] H.K. Sezer, L. Li, M. Schmidt, A.J. Pinkerton, B. Anderson, P. Williams, *Effect of beam angle on HAZ, recast and oxide layer characteristics in laser drilling of TBC nickel superalloy*, International Journal of Machine Tools and Manufacture 46 (15) 19721982, 2006.
- [16] <http://www.mrl.columbia.edu/ntm/pgIndex.html>