

## PERFORMANCE IMPROVEMENT IN WCDMA SYSTEM SUBJECTED TO INCREASED DATA RATE AND INTERFERENCE CHANNELS USING COMPENSATION FOR ERRORS

**F. O. Ombongi, P. L. Kibet and S. Musyoki**

<sup>2</sup>Department of Telecommunication and Information Engineering, Jomo Kenyatta University of Agriculture and Technology, Nairobi, Kenya

E-mail: onkundifilo@yahoo.com

### Abstract

Most mobile operators have rolled out third generation (3G) networks which have more benefits compared to first and second generation networks since it can support voice, data and multimedia applications. The rise in demand for integrated services (capacity) has led to interchannel and inter-symbol interference among the users and on transmission the signal is degraded again due to interference channels along the path. The digital signal processing techniques are applied in third generation (3G) mobile communication systems to reduce interference and power consumption. The main objective is to develop wideband code division multiple access (WCDMA) system model whose performance has been improved by applying compensation for errors. This model is subjected to an interference channels and data rate increased from 64kbps to 2Mbps. The computer simulation tool (Matlab 7.8) is used to develop and evaluate the bit error rate (BER) performance of the system. The model is developed in Simulink which has blocks in the communication blockset which have parameters for simulation of the system. The bit error rate (BERs) is calculated at the receiver with/without compensation of errors. For a data rate of 2Mbps, the average error rate is 0.4817 with error correction and 0.5165 without correction in an additive white Gaussian channel (AWGN). In conclusion, the performance of the WCDMA model improves by 6.74% at 2Mbps, 5.59% at 384kbps, 5.79% at 144kbps and 5.32% 64kbps. This shows that the performance of the system improves by using this method when the data rate is increased in an additive white Gaussian channel. It also performs better at higher rates than in lower rates.

**Key words:** Bit error rate, interference channels, Third generation (3G), wideband code division multiple access

### 1.0 Introduction

The wideband code division multiple access (WCDMA) is a third generation (3G) air interface whose specifications were developed by the 3G partnership Project (3GPP) in the year 2000. It is a standard of the International Telecommunication Union (ITU) derived from the CDMA called International Mobile Telecommunication of 2000 (IMT-2000) direct spread spectrum and has received wide adoption all over the world. The current WCDMA utilizes 5MHz but there are 10MHz and 20MHz bands allocated by the International Telecommunication union (ITU) to offer flexibility of operation, (Keiji Tachikwa, 2002).

This technology is based on direct sequence spread spectrum (DSSS) transmission where the user data is directly multiplied by a code which is a pseudo-random sequence of  $\pm 1$ . When the signal arrives at the receiver, the same code is used to extract the original signal from the incoming wideband signal. The frequency of the pseudo random sequence is very high compared to the frequency of the data so that spreading of the signal to 5MHz bandwidth is possible.

The direct sequence code division multiple access (DS-CDMA) is the form used for the air interface in the UMTS known as WCDMA with a chip rate of 3.84Mcps. The variable spreading and multimode connection are used in WCDMA to make the system support high data rates up to 2Mbps. The chip rate of the pseudo-random sequence is used to lead a carrier of 5MHz bandwidth.

The system is required to overcome the effects of multiple users with different propagation characteristics transmitting simultaneously. This is often referred to as the near far problem where a remote user can easily be drowned out by a user that is physically much closer to the base station. The main features include attenuation due to increase in distance from the receiver, fading variations due to specific features of the environment and fading variations due to the movement of the mobile device. These interference channels cause errors in the system, Jeffrey, B. *et al*, (2004).

In most digital communication systems such as WCDMA, it is required that there is an efficient use of the channel bandwidth. This requirement is fulfilled by a bandwidth saving modulation technique called quadrature phase shift keying (QPSK). In this modulation type, the information to be transmitted is contained in the phase of the carrier and occupies any of the four equally spaced phases of 0,  $\pi/2$ ,  $\pi$ , and  $3\pi/2$  in gray coding. The equation for QPSK from [3] is given as:

$$s_{QPSK}(t) = \sqrt{E_s} \cos[(i-1)\frac{\pi}{2}\phi_1(t) - \sqrt{E_s} \sin(i-1)\frac{\pi}{2}\phi_2(t)] \quad i = 1,2,3,4 \quad \dots\dots\dots(1)$$

Where  $\phi_1(t) = \sqrt{\frac{2}{T_s}} \cos 2\pi f_c t$  and  $\phi_2(t) = \sqrt{\frac{2}{T_s}} \sin 2\pi f_c t$

Due to the spectral spreading of the transmitted signal, if it has large envelope variations it will also create large envelope fluctuations as it propagates through the transmitter. These envelope variations can be eliminated by using the pulse shaping filter placed at the transmitter and receiver end.

This filter is important in modern wireless communication to spectrally shape the transmitted signals which reduces the spectral bandwidth. The pulse shaping is a spectral processing technique where the portion of the out of band power is reduced for low cost, reliable, power and spectrally efficient mobile radio communication systems. In addition, this filter can reduce the adjacent channel interference also known as inter-symbol interference.

There are two types of pulse shaping filters which ensures that inter-symbol interference is eliminated namely; the raised cosine filter and the square root raised cosine filter. The impulse or time domain response of the raised cosine filter and the square root raised cosine filter in Crawford, J. A. (2008), are given by equations 2-4:

$$h_{RC}(t) = \frac{\sin(\frac{\pi t}{T}) \cos(\frac{\pi \alpha t}{T})}{\frac{\pi t}{T} [1 - (\frac{2\alpha t}{T})^2]} \quad \dots\dots\dots(2)$$

This expression can be simplified further by introducing the sinc function ( $\text{sinc } x = \frac{\sin x}{x}$ )

$$h_{RC}(t) = \text{sinc}\left(\frac{\pi t}{T}\right) \frac{\cos(\frac{\pi \alpha t}{T})}{1 - (\frac{2\alpha t}{T})^2} \quad \dots\dots\dots(3)$$

The sinc function in the response of the filter ensures that the signal is band-limited. The time domain or impulse response of the square root raised cosine filter is given as;

$$h_{RRC}(t) = \frac{\sin[\pi(1-\alpha)t + 4\alpha(\frac{t}{T})] \cos[\pi(1+\alpha)\frac{t}{T}]}{\frac{\pi t}{T} [1 - (\frac{4\alpha t}{T})^2]} \quad \dots\dots\dots(4)$$

In the development of the WCDMA system model, the square root raised cosine filter is used in the transmitter and receiver section so that the overall response of the system reduces to that of the raised cosine filter such that;

$$h_{RC}(t) = h_{RRC}(t)h_{RRC}(t) \quad \dots\dots\dots(5)$$

**1.1 Error Detection and Correction**

The channel used for transmission of a signal introduces noise and interference which corrupts the signal transmitted through it. On reception, the signal delivered is an approximate of the transmitted signal. This implies transmitting a signal over noisy channels will result in some errors appearing on the received information. Majority of these bit errors occur because of transmission over a noisy channel and their number depends on the amount of noise and interference present in the communication channel.

For a quality information transfer system, these errors are supposed to be detected and corrected using channel coding techniques. The error correction methods play a significant role in mobile communication systems to ensure that a high quality of service (QOS), reliable transmission is maintained. In addition, this will improve the performance of the system as the error rates are minimized in the system. These techniques contain error correction codes which can be simulated on wireless communication systems and investigate their performance on data signals which are used in wireless systems. The examples of wireless systems include mobile communication, internet, radio and TV broadcasting.

The convolution coding is one of the methods which are applied in wireless systems to detect and correct the errors encountered in the system. When this method is used together with sequential decoding it offers an error detecting and correcting characteristic without additional complexity. Therefore, an error correcting

mechanism compensates for the errors present in a system when transmission is done over a noisy channel, (Joseph, 1976).

The wireless communication systems' efficiency in the presence of wideband noise spectral density of  $N_o$  is usually measured by the received information bit energy-to-noise ratio ( $E_b/N_o$ ) required to obtain a specified error rate. This proportion can be determined by expressing it in terms of the received modulated signal power (P) divided by  $N_o$ .

$$\frac{E_b}{N_o} = \frac{P}{N_o} = \frac{1}{R_{bps}} \dots\dots\dots(6)$$

Where  $R_{bps}$  is the data rate of the user information signal transmitted in bits per second (bps) from [5] and [6], [7], [8].

## 2.0 Methodology

The computer simulation tool, Matlab version 7.8 is used to develop and simulate the WCDMA system model that has the capability of transmitting information at a data rate of 64kbps to 2Mbps. The Communication and Simulink block sets are used to develop the model shown in Figure 1.

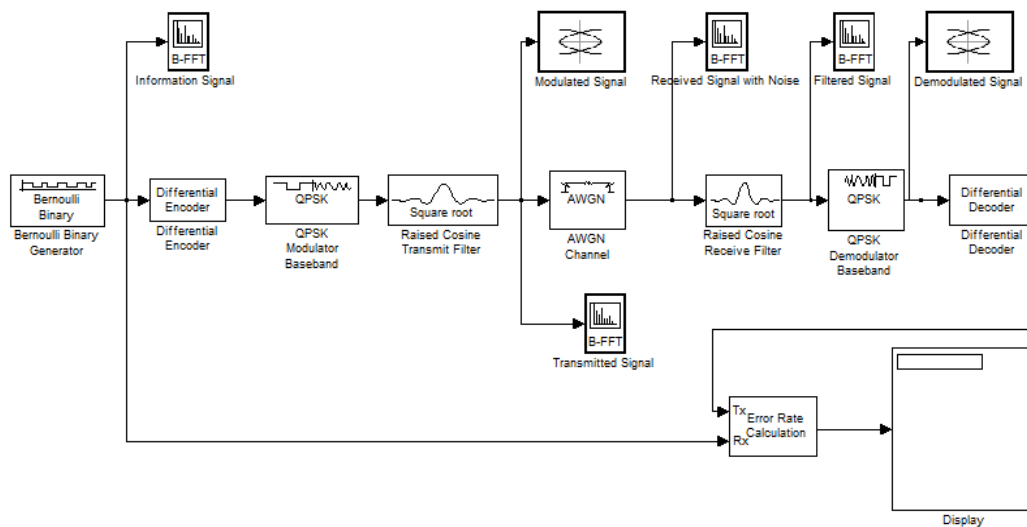

Figure 1: WCDMA simulation model without the error correction scheme

During error correction, the convolutional encoder block is placed between the differential encoder and the QPSK modulator in the transmitter part and the viterbi decoder block placed between the differential decoder and the error rate calculator as shown in Figure 1.

### 2.1 Bernoulli Binary Generator

It uses Bernoulli distribution to generate random binary numbers. The distribution has a parameter  $p$  (probability) which produces zero and one when the probability is  $1-p$ . The mean value of this type of distribution is  $1-p$  and the variance is given as  $p(1-p)$ . When  $p$  is specified by a probability of a zero parameter, there can be any real number between zero and one produced. The user data rate is set in this block in the sampling time parameter which is given as:

$$\text{Sampling time} = \frac{1}{R_b} \text{ where } R_b \text{ is the data rate}$$

### 2.2 Differential Encoder

It encodes the binary input signal and its output is the logical difference between the present input and the previous output. In this block the initial condition is set at zero (0).

### 2.3 Convolutional Encoder

It encodes a sequence of binary input vectors to produce a sequence of binary output vectors and it can process multiple symbols at any given time. It is specified by the Trellis structure parameter which includes constraint length, generator polynomials and the feedback connection polynomials. This is done with the *poly2trellis* command which located in the Trellis structure field of the encoder in Simulink. In the simulation of

this system the constraint length is taken as 7, the code generator polynomials are 171 and 133 in octal numbering system.

#### 2.4 QPSK modulator Baseband

It does the modulation of the signal by utilizing quaternary phase shift keying technique whose output is a baseband representation of the modulated signal. The QPSK demodulator block is placed at the receiver to demodulate the signal that is modulated with QPSK modulation method in the transmitter section. The input to the demodulator must be a discrete-time complex signal and can be either a scalar or a frame-based column vector.

#### 2.5 Raised Cosine Transmit Filter

It up-samples and filters the input signal using a normal raised cosine FIR filter or a square root raised cosine FIR filter. For this system model the square root raised cosine filter is used in the transmitter and receiver section.

The following parameters are set in the raised cosine transmit filter block:

- (i) The type of the filter is set as square root
- (ii) The roll off factor( $\alpha$ ) as 0.22
- (iii) The group delay (D) which is the number of symbol periods between the start of the filter's response and the peak of the filter's response is set as 4.  
The up sampling factor, N, is 8 and the length of the filter's impulse response can be determined from the expression  $2 \times N \times D + 1$ . Therefore, the length of this filter is 65.
- (iv) The gain of the filter which indicates how the block will normalize the filter coefficients is also selected between 'user specified' and 'normalized'. This study uses normalized so that the block uses an automatic scaling.

#### 2.6 Viterbi Decoder

It decodes the user information that was convolutionally encoded at the transmitter end. It can process multiple input symbols at any given time for a faster performance of the system. The decoder is also specified by the trellis structure parameter, decision type, trace back depth and operation mode. For this study the Trellis structure is *poly2trellis (7, [171 133])*, trace back depth as 34 and operation mode as continuous.

#### 2.7 Error Rate Calculator

It is used to determine the bit error rate (BER) by comparing the input data from the transmitter with input data from the receiver. The error rate is calculated as a running statistic by dividing the total number of bits that are received in error by the total number of bits generated from the source of information.

This block can determine either the symbol or bit error rate as the magnitude difference between the errors received in error and the total number of bits transmitted is not considered. If the inputs are bits, then the block computes the bit error rate. If the inputs are symbols, then it computes the symbol error rate.

#### 2.8 Discrete Time Eye Diagram Scope

It displays multiple traces of a modulated signal to produce an eye diagram. The block can also be used to show modulation characteristics of a signal such as pulse shaping or channel distortions. It has one input port which feeds data of the type double, single, boolean, base integer and fixed-point. For sample-based mode, the input signal must be a scalar value and n frame-based mode; the input signal must be a column vector or a scalar value.

#### 3.0 Results

The table below gives the results of the system simulation using the data rates 64kbps, 144kbps, 384kbps and 2Mbps. These data rates are applied in the system separately by setting the sampling time in Bernoulli generator as  $\frac{1}{R_b}$  where  $R_b$  is the data rate. The signal of the Bernoulli generator can be shown at various stages in the system when a data rate of 2Mbps is used as shown below.

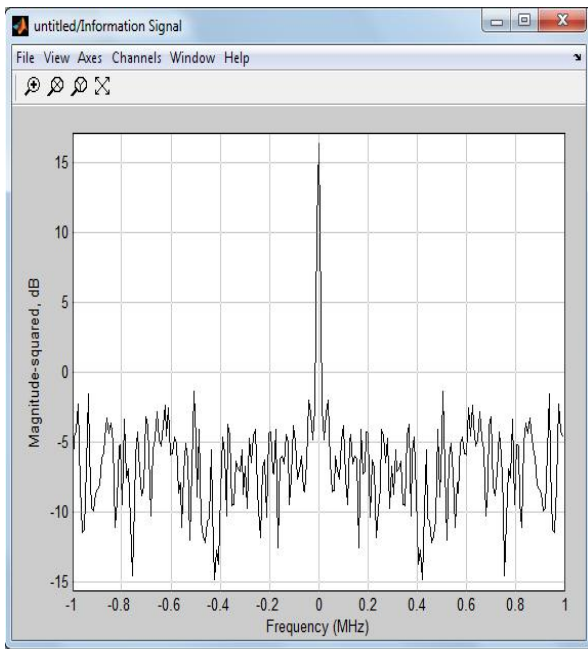

User information

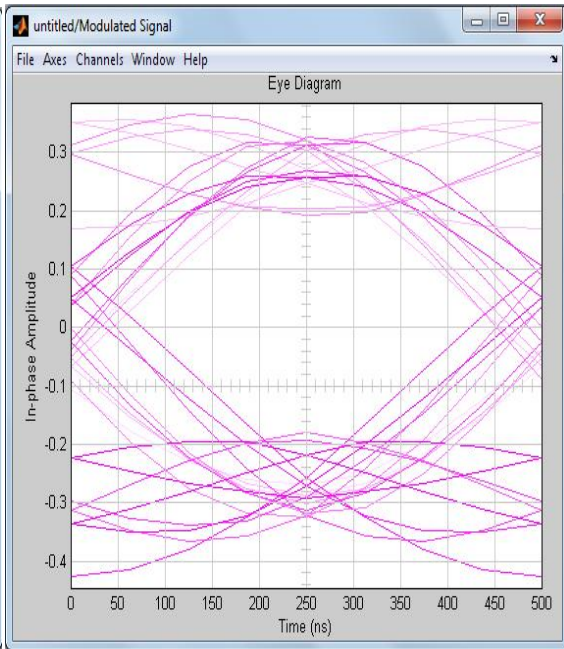

Modulated data displayed by discrete eye scope

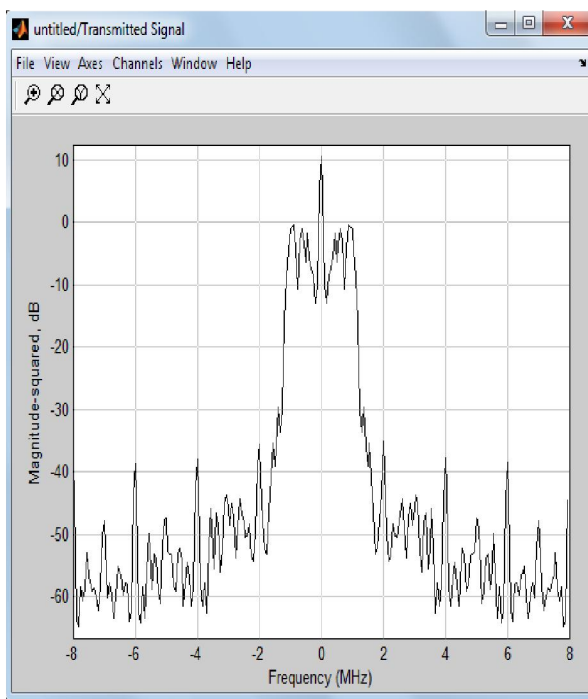

Transmitted signal

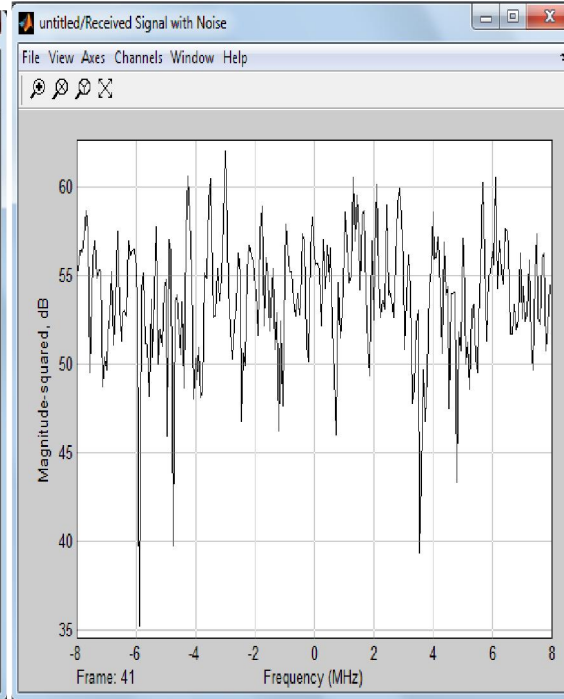

Received signal (Corrupted by Gaussian noise)

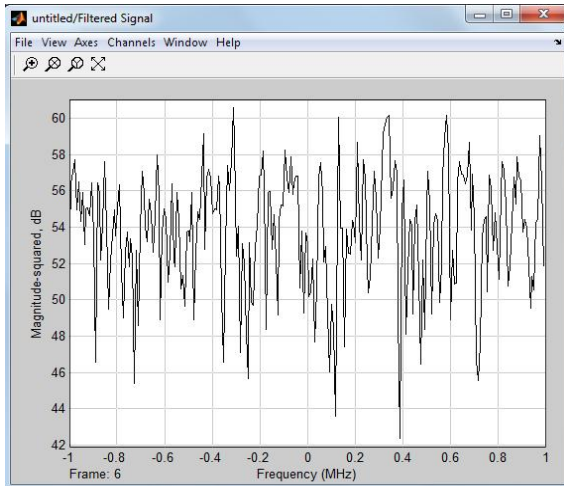

Filtered signal

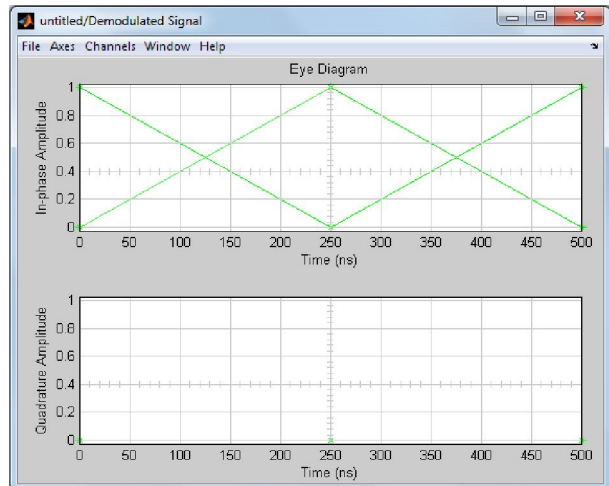

Demodulated Signal

Table 1: Bit Error Rates at different user data rates with/without convolution coding

User Data Rate	BER Without Convolution coding	BER with Convolution coding	Percentage change
64kbps	5.1546e-001	4.8804e-001	5.32
144kbps	5.1653e-001	4.8662e-001	5.79
384kbps	5.1546e-001	4.8662e-001	5.59
2Mbps	5.1653e-001	4.8170e-001	6.74

The comparison of the BERs at different data rates with or without error correction is shown in a graph below:

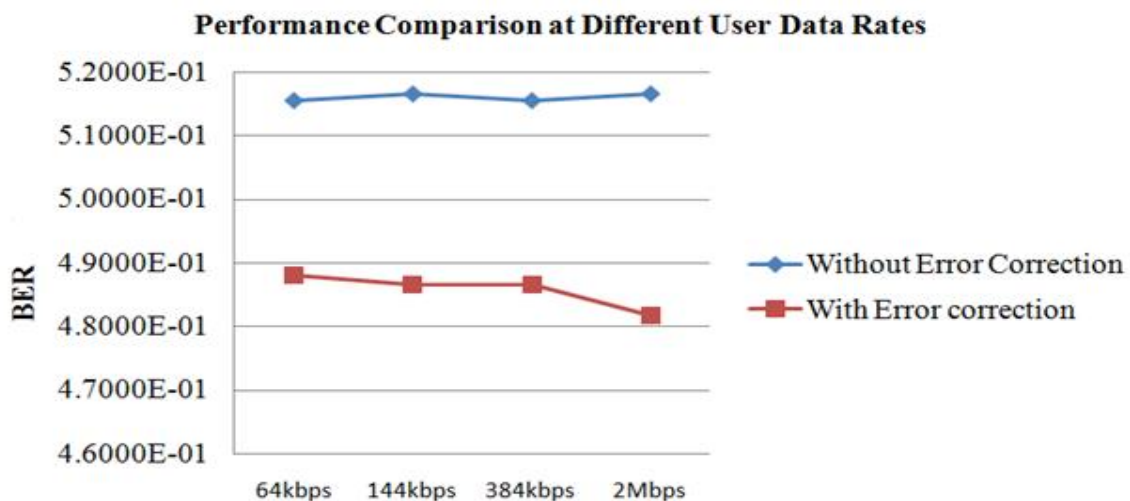

#### 4.0 Discussion and Conclusions

The performance of a wireless system is determined by the bit error rates (BER) calculated at the receiver end by comparing the transmitted and received signals. The lower the BER the higher the performance of the system and there will be quality provision of services. Therefore, the WCDMA has been simulated above with or without channel coding has shown improvement when the convolution error correction scheme is incorporated in the system.

It can be seen that the performance of the WCDMA model improves by 6.74% at 2Mbps, 5.59% at 384kbps, 5.79% at 144kbps and 5.32% 64kbps. This shows for provision of wireless services such as video streaming, music downloads and multimedia messages require compensation for errors in the presence of interference channels in the transmission path. The error detection and correction scheme plays a significant role in the decrease of the error rates in the presence of additive white Gaussian noise and multipath fading channels.

## References

- Keiji, T. (2002). *WCDMA Mobile Communication Systems*.: Wiley Publications.
- Jeffrey, B. et al, (2004). *Convergence Technologies for 3G Networks IP, UMTS, EGPRS and ATM*. West Sussex, England: John Wiley & Sons, 2004.
- Masud, M. A. et. al, (2010). "Bit Error Rate Performance Analysis on Modulation Techniques of Wideband Code Division Multiple Access." *Journal of Telecommunications*, vol. **1**(2).
- Crawford, J. A. (2008). *Advanced Phase Lock Techniques*. London: Artech House, Boston.
- Joseph P. O. (1976). *Error Control Coding Handbook*. San Diego: Linkabit Corporation.
- Nabeel, A. and Abdul, B. (2012). "Implementation and Analysis of Convolution Codes using MATLAB." *International Journal of Multidisciplinary Sciences and Engineering*, vol. **3**(8).
- Himmat, K. and sandya, S. (2012). "An Implementation of a Forward Error Correction Technique using Convolution Encoding and Viterbi Decoding." *International Journal of Soft Computing and Engineering*, vol. **2**(5).
- Jai, K. and Anita, S. (2013). "Simulation and Evaluation of Convolution encoder for different noisy Channel over Wireless Communication network in CDMA Environment." *International Journal of Advanced Research in Computer Engineering and Technology*, vol. **2**(2).